

A vertical decorative strip on the left side of the slide, divided into four colored sections: yellow (top), red (middle), green (bottom), and blue (bottom-most).

**Ultrasonic Intensification of CO<sub>2</sub> Stripping**  
*(Ultra Stripping)*

**Jiru Ying, Dag Eimer**

June, 2016

# Basics

## ■ Bubble surface

$$P_s = \frac{2S}{R}$$

very large for small bubbles

## ■ Cavitation promoted by ultrasonics

Primary  
equilibrium  
affected

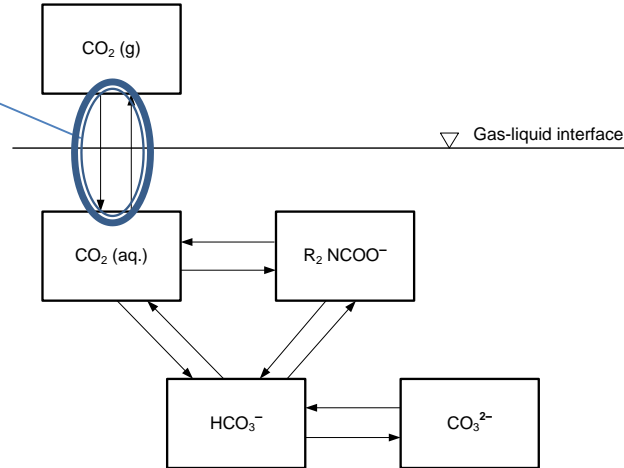

**EQUILIBRIUM SYSTEM(S)**

# Test Rig

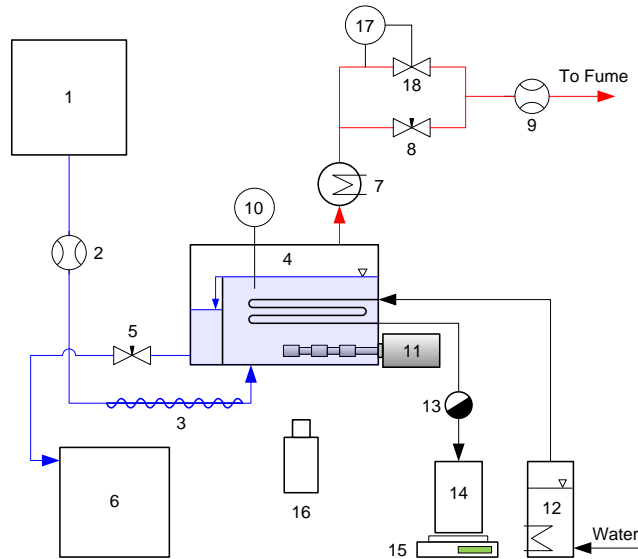

**Figure 1. Schematic diagram of the reboiler rig with ultrasonics.**

- 1, Rich amine feed tank; 2, Liquid flow meter; 3, Preheat unit; 4, Glass kettle reboiler; 5, Needle valve;  
6, Lean amine receiving tank; 7, Gas-liquid separator; 8, Needle valve; 9, CO<sub>2</sub> flow meter;  
10, Various sensors (P, T) in liquid and gas; 11, Ultrasound unit; 12, Electric steam generator; 13, Steam trap;  
14, Condensed steam receiving tank; 15, balance; 16, High speed camera; 17, Pressure controller; 18, Solenoid valve.  
(Blue line is liquid phase and red line is gas phase)

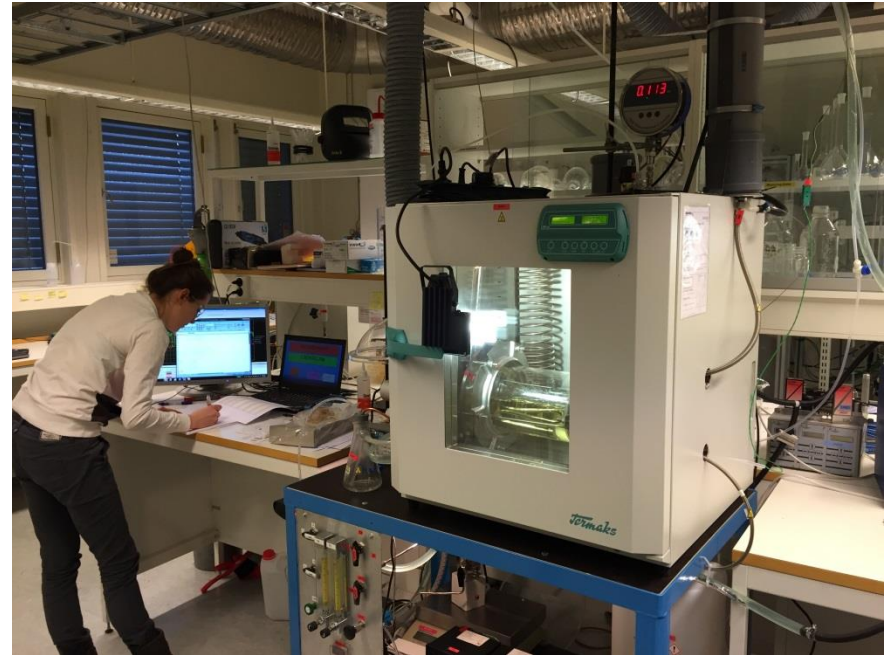

**Figure 2. Photo of the rig**

# Typical Experimental Video (On/Off valve P control)

- $P=0.5$  bara
- $\alpha=0.25$
- $f=28k$  1/s
- $I=425w$
- $t_{on}=1$  s
- $t_{off}=3$  s

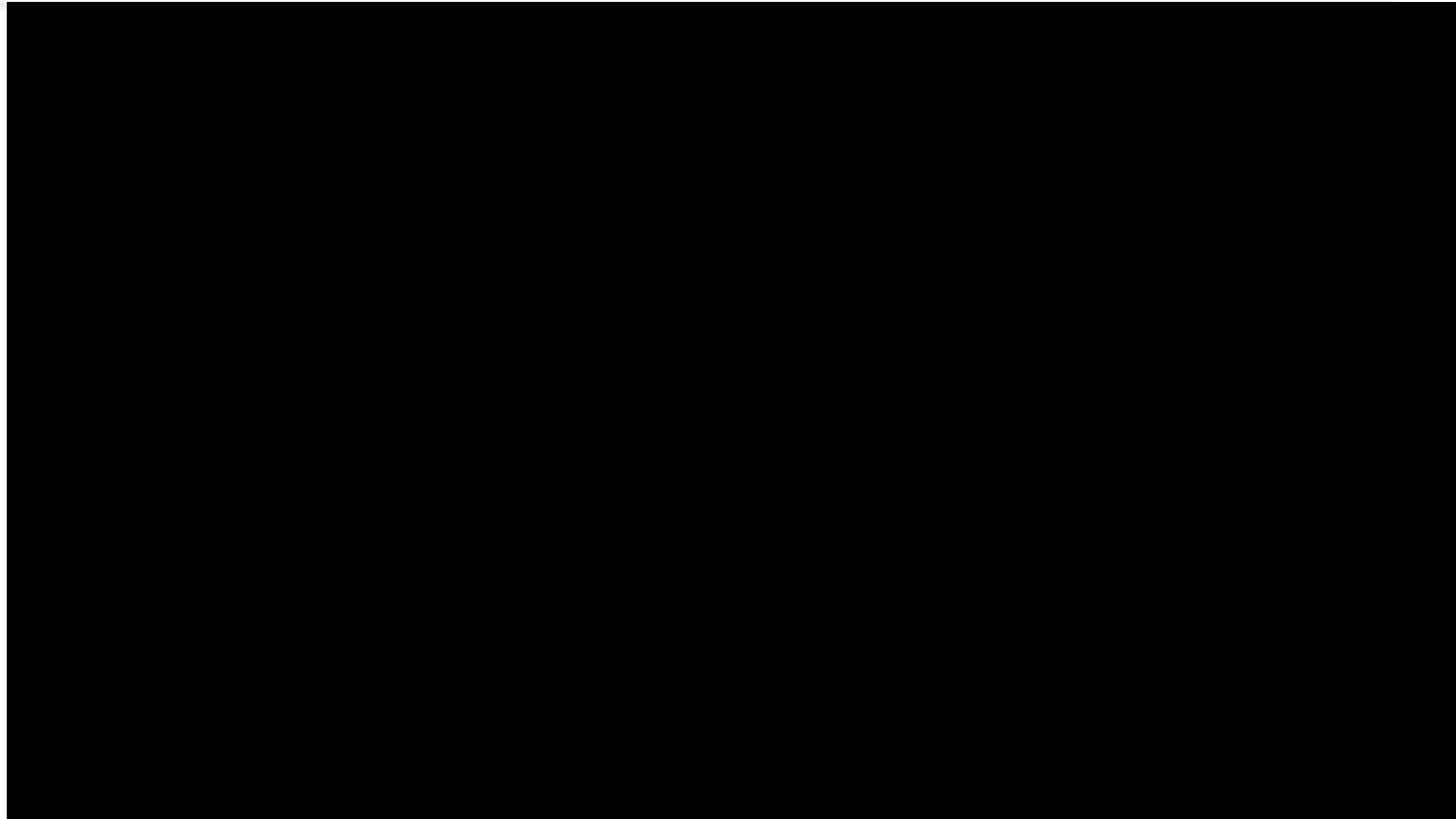

# Key Figures

---

- Specific energy saving
- Improved recovery
  - Leading to savings due to lower circulation rate
- Rate of CO<sub>2</sub> stripping in reboiler increased by
  - 5 x

# Close to industry

